

Model T-2 Yacht Horn

Kahlenberg Chimetone Air Horns all utilize more than one projector or “trumpet” in their design. These projectors each produce a different fundamental frequency which combine to produce powerful, distinctive, musical chords. To hear a Chimetone Air Horn is to realize that the sound of a vessel can be one of its most impressive aspects. The Model T-2 Air Horn is designed for the most discriminating yachtsman. It is made entirely of bronze and brass, and is triple plated for a deep chrome finish.



TECHNICAL DATA

Fundamental Frequency: 208, 261, 311 Hz
S.P.L. : (1/3 Octave @ 1 Meter): 135 dB

Air Consumption:

56 C.F.M. @ 100 p.s.i., 27 l/s @ 7 bar

Air Pressure Required:

100 to 250 p.s.i., 7 to 17 bar
(Higher pressures with optional regulators)

Electrical Power Required:

Any standard A.C. or D.C. Voltage

Material: Cast Bronze and Spun Brass

Net Weight: 75 lbs., 34 kg.,

Finish:

White Powdercoat or Chrome Plate

- **FOR VESSELS LESS THAN 75 METERS IN LENGTH**
- **MEETS OR EXCEEDS IMO REQUIREMENTS**
- **OPERATES ON A WIDE RANGE OF AIR PRESSURE**
- **HIGHLY RELIABLE, VIRTUALLY NO MAINTENANCE**
- **OPTIONAL DIRECTLY MANIFOLDED MANUAL/SOLENOID VALVES, AIR STRAINER**

Conforming to International Maritime Regulations
For Vessels Less Than 75 meters in Length.

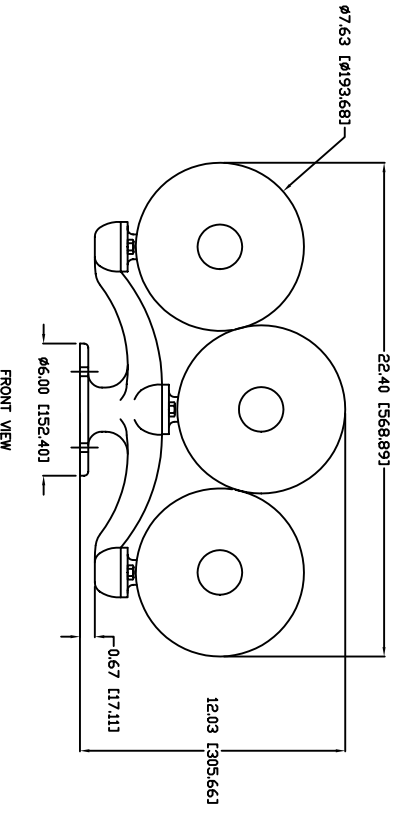
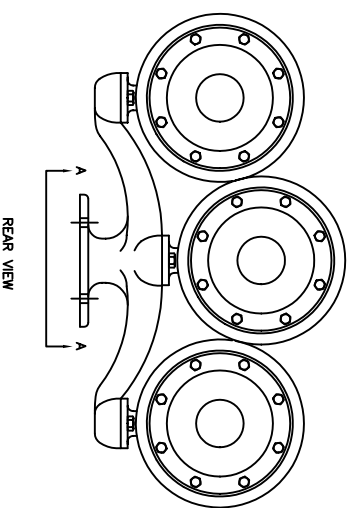
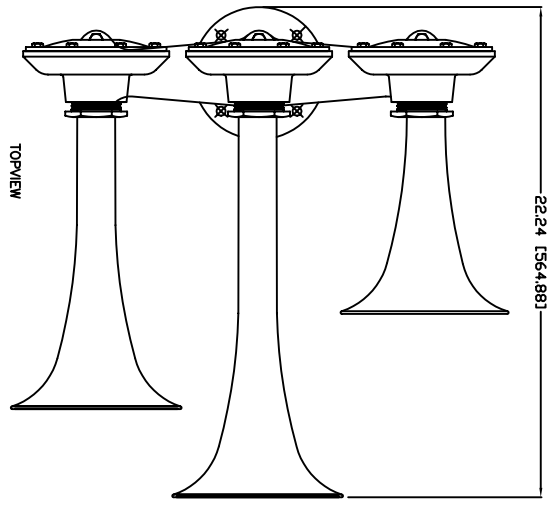
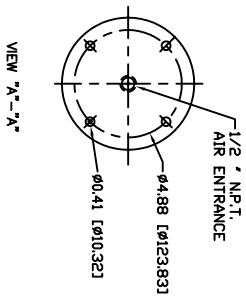

TECHNICAL DATA

Frequency: 349, 265, & 212 Hz
 Sound Pressure Level (dB(A) at 1 meter): 140dB
 Sound Pressure Level (1/3 octave at 1 meter): 131dB
 Air Consumption: appx. 60 C.F.M. @ 150 P.S.I.
 Air Pressure Req: 100 To 250 P.S.I.
 Electric Power: Any Standard A.C. or D.C. voltage
 Material: Spun Brass & Cast Bronze
 Net Weight: 54 Lbs.
 Shipping Weight: 96 Lbs.

Price: \$ _____ U.S.D. Net. Ea.
 (Valid for 60 days, F.O.B. Two Rivers, WI, U.S.A.)



KAHLENBERG BROS. CO. TWO RIVERS, WI. U.S.A.

**OUTLINE DIMENSIONS
MODEL T-2 AIRHORN**

| DATE | DRWG. NO. | REV. |
|----------|-----------|-------|
| 04/12/01 | 3-6104 | A EMK |