

### Model S-2 Air Horn

Designed for use on vessels up to 75 Meters in length, the Kahlenberg Model S-2 Air Horn is an extremely durable unit built for a lifetime of trouble-free service. The most economical solution for signaling where compressed air is readily available, this horn is also available as Model S-2CV including manual/electric combination valve and air strainer.



#### TECHNICAL DATA

Fundamental Frequency: 266 Hz  
S.P.L. : (1/3 Octave @ 1 Meter): 132 dB

Air Consumption:  
17 C.F.M. @ 100 p.s.i., 8 l/s @ 7 bar

Air Pressure Required:  
100 to 250 p.s.i., 7 to 17 bar  
(Higher pressures with optional regulators)

Electrical Power Required:  
Any standard A.C. or D.C. Voltage

Material: Cast Bronze and Spun Brass

Net Weight: 12 lbs., 5.5 kg.,  
S-2CV: 14 lbs., 6.35 kg.

Finish:  
None, White Powdercoat or Chrome Plate

Dimensions:  
16.5" X 7.6" X 8.3" (417x194x211)

- **FOR VESSELS LESS THAN 75 METERS IN LENGTH**
- **MEETS OR EXCEEDS IMO REQUIREMENTS**
- **LOW AIR CONSUMPTION, OPERATES ON A WIDE RANGE OF AIR PRESSURE**
- **HIGHLY RELIABLE, VIRTUALLY NO MAINTENANCE**
- **OPTIONAL DIRECTLY MANIFOLDED MANUAL/SOLENOID VALVES AND AIR STRAINER FOR EASE OF INSTALLATION**

Conforming to International Maritime Regulations  
For Vessels Less Than 75 Meters in Length

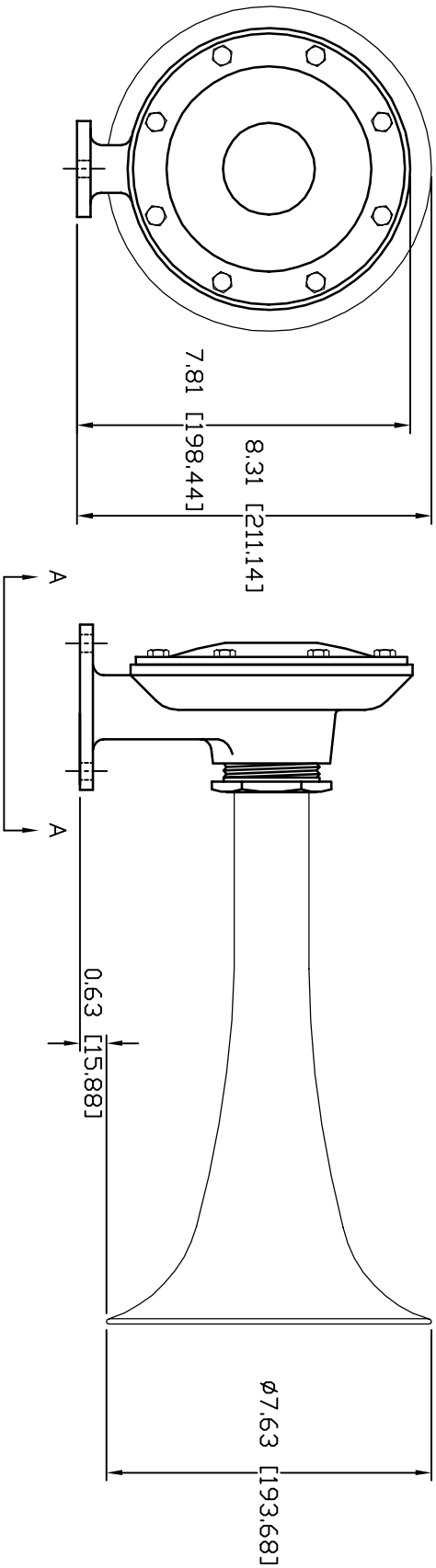
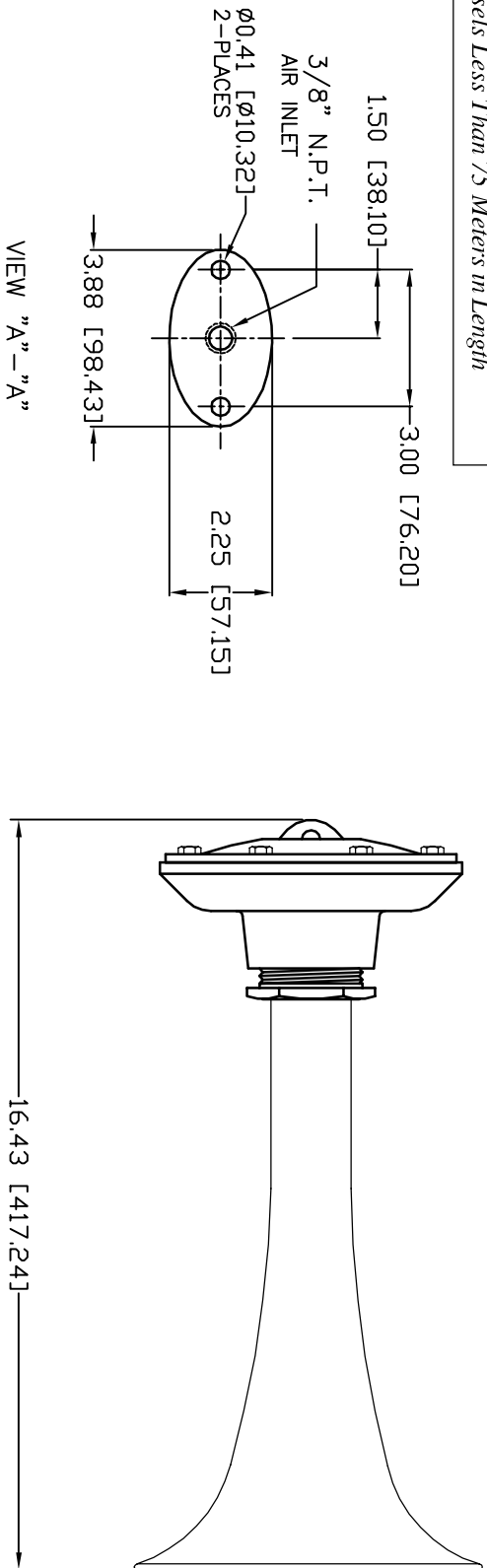

**TECHNICAL DATA**  
 Frequency: 266 Hz  
 Sound Pressure Level (dB(A) at 1 meter): 136.5dB  
 Sound Pressure Level (1/3 octave at 1 meter): 132dB  
 Air Consumption: approx. 21 CFM @ 150 P.S.I.  
 Air Pressure Req./A: N/A  
 Electric Power: N/A  
 Material: Spun Brass & Cast Bronze  
 Net Weight: 12.00 Lbs.  
 Shipping Weight: 15.00 Lbs.

Price: \$ U.S.D. Net. Ea.  
 (Valid for 60 days, F.O.B. Two Rivers, WI, U.S.A.)

**Kahlenberg's**  
 KAHLBERG BROS. CO. TWO RIVERS, WI. U.S.A.

**MODEL S-2  
 AIRHORN**

DATE	DRWG. NO.	REV.
04/11/01	3-6093	B EMK

Conforming to International Maritime Regulations  
For Vessels Less Than 75 Meters in Length

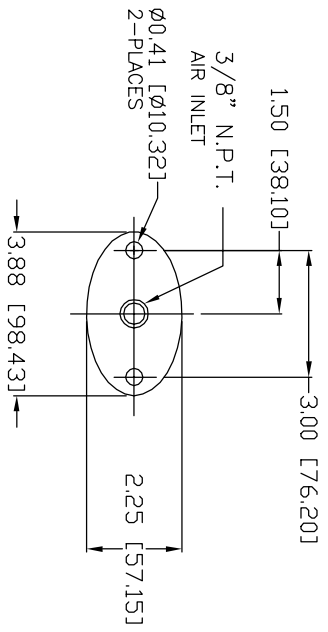

HORN BASE FOOTPRINT

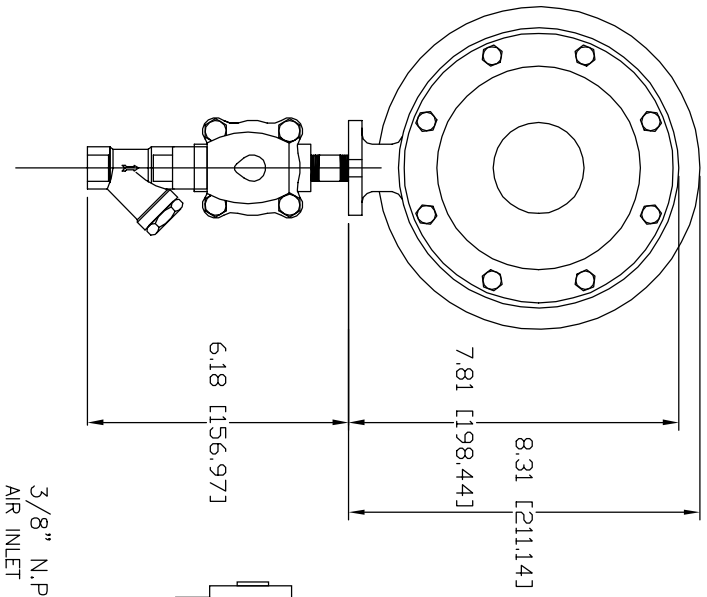
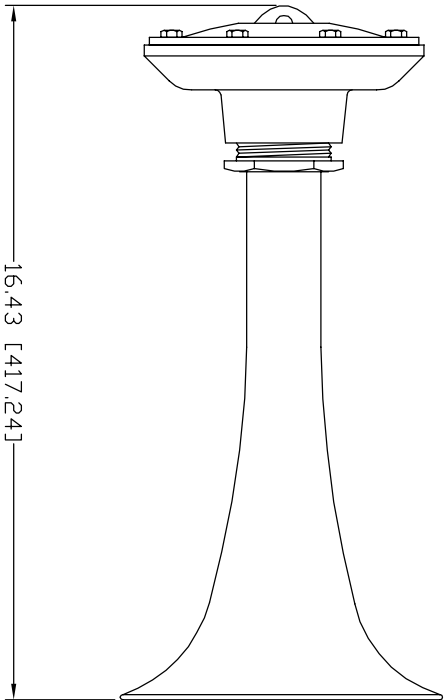

3/8" N.P.T.  
AIR INLET

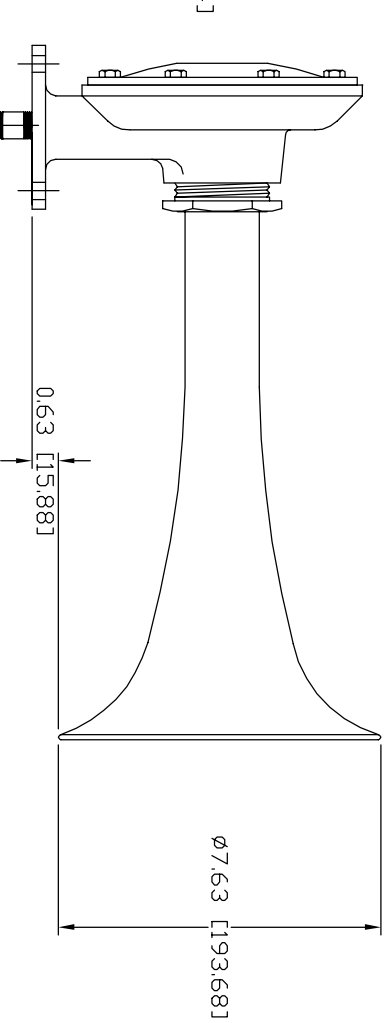

**TECHNICAL DATA**

Frequency: 266 Hz  
Sound Pressure Level (dB(A) at 1 meter): 136.5dB  
Sound Pressure Level (1/3 octave at 1 meter): 132dB  
Air Consumption: appx. 21 CFM @ 150 P.S.I.  
Air Pressure Req: 100 To 250 P.S.I.  
Electric Power: N/A  
Material: Spun Brass & Cast Bronze  
Net Weight: 14.00 Lbs.  
Shipping Weight: 18.00 Lbs.

Price: \$ U.S.D. Net. Ea.  
(Valid for 60 days, F.O.B. Two Rivers, WI, U.S.A.)



KAHLENBERG BROS. CO. TWO RIVERS, WI. U.S.A.

OUTLINE DIMENSIONS  
MODEL S-2 CV AIRHORN

DATE	DRWG. NO.	REV.
04/12/01	3-6094	B EMK