

Electric Piston Horn

AUDIBILITY RANGE: 2 NAUTICAL MILES
CERTIFIED FOR CLASS I AND II MARINE VESSELS



- Piston horn is electrically powered and IMO certified for vessels over 75 meters and over 200 meters in length
- Horn construction: High strength aluminum bell, supporting frame, aluminum crankcase, stainless steel cylinder and fasteners
- Self draining design to prevent condensation and corrosion
- Oil free, heated crankcase and piston cylinder assembly
- Motor is totally enclosed, marine type, IP56, insulation class F and equipped with anti-condensation strip heater
- Motor starter (contactor) comes with solid state, temperature compensated relay that is field adjustable with thermal overload protection

* Signal will produce a sound pressure level of approximately 70 dB @ 8 km in calm, cool conditions without topographical interference. Signal strength at distance can vary dramatically depending on environmental and geographical conditions. Please consult factory for more detailed information.

Control and Heater:	120/230V [50-60 Hz]
SPL (Loudness) on Total:	147 dBA @ 1 meter
SPL (Loudness) 1/3 Octave:	> 143 dB @ 1 meter
Power Consumption:	15 amp on 460/3/60 (other voltage available)
Audibility:	2 nautical miles (IMO)
Fundamental Frequency:	130 Hz ± 20 Hz
Tone (Musical Note):	C ₃
Operating Voltage:	460/3/60 (other voltages available)
Operating Temperature:	-40°C to +45°C [-22°F to +113°F]
Finish:	Alodine Treated, Primed and Enamel coated
Degree of Protection:	IP 56
Basic Dimension:	1018x635x844mm [40x25x33"]
Net Weight:	100 kg [220 lbs]

Kahlenberg Brothers Company

1700 12th Street, P.O. Box 358
Two Rivers, Wisconsin, 54241
Phone: (920) 793-4507 / Fax: (920) 793-1346

Website: www.kahlenberg.com Email: info@kahlenberg.com

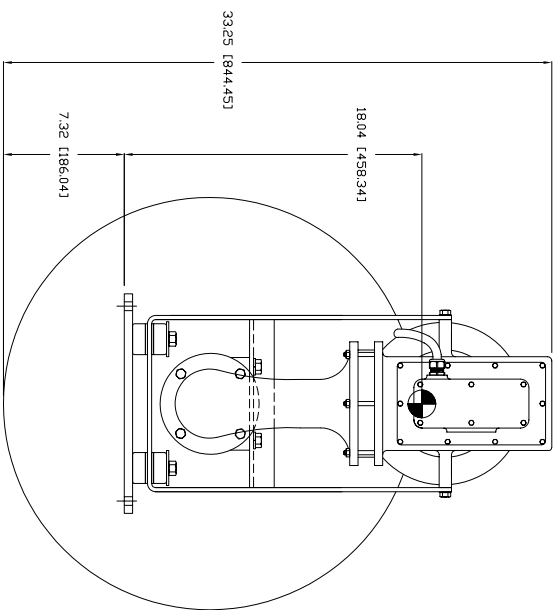
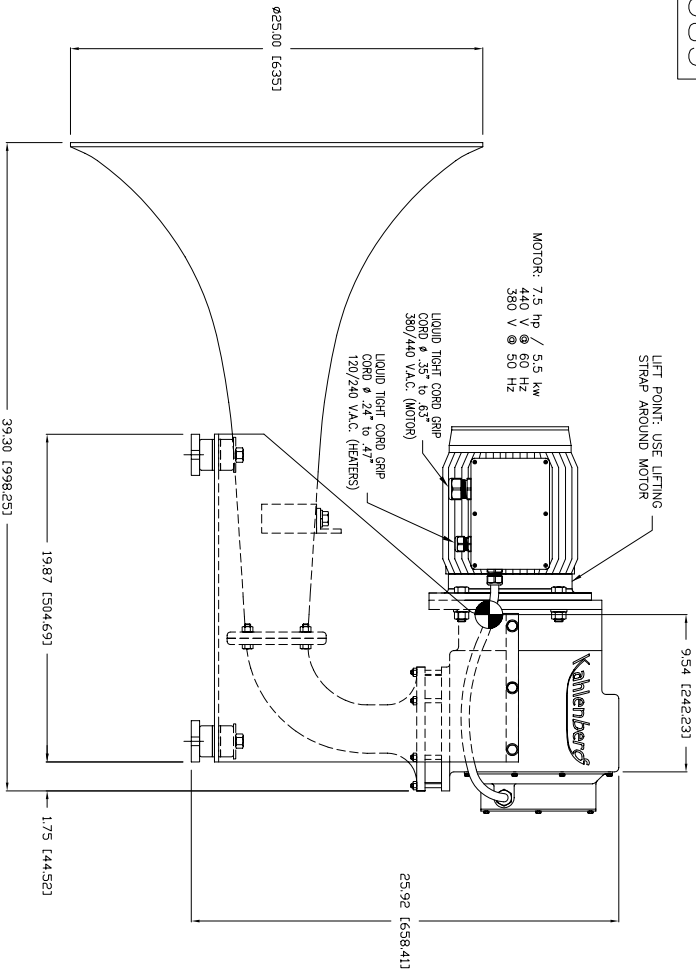

SIDE VIEW

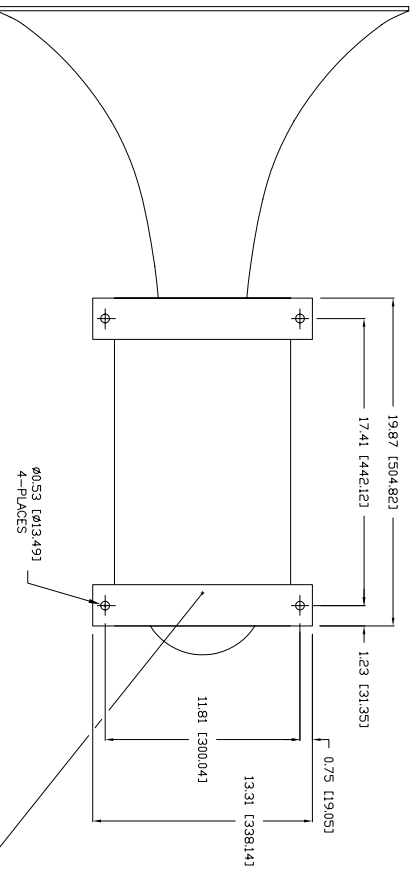

BOTTOM VIEW



REV.	BY	DATE	DESCRIPTION	APP'D.
A	ZN	01/18/08	CHANGED MOTOR ELECTRICAL ENCLOSURE, ADDED CABLE & CORD GRIPS FOR HEATERS	EMK

MATERIAL: TYPE 356 CAST ALUMINUM.
 MOUNTING BASE A-36 STEEL,
 FASTENERS 316 STAINLESS STEEL
 FINISH: GREY EPOXY SILOXANE
 EST. WEIGHT 220 Lbs. 100 Kg.
 S.P.L. Loudness: 147 dBA @ 1 Meter, 143 dB (1/3 Octave Band) @ 1 Meter.
 Fundamental Frequency: 130 HZ

P.L. 3-6065 & 3-6073

 KAHLENBERG BROS. CO. TWO RIVERS, WISCONSIN 53411				
OUTLINE DIMENSIONS KPH-130C PISTON HORN 130 HZ				
DR.	DATE	CKD.	SCALE	DRWG. NO.
ZN	10/24/05	EMK	N.T.S.	3-6383
				REV.
				A